

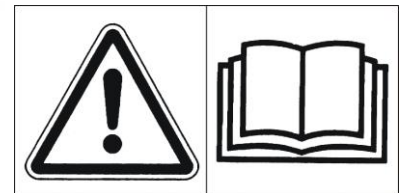

MOTOR HOES

FPM 512

HONDA ENGINE
KIPOR ENGINE



INSTALLATION/HANDLING/MAINTENANCE

№ 46328
12.2010.

SERBIA

E-mail: razvoj@fpm-agromehanika.rs
info@fpm-agromehanika.rs
fpmbolj@eunet.rs

Internet: www.fpm-agromehanika.rs

Symbols, Identification (name) plate

Please, fill-in

Machine type, number
Machine ID number
.....
Engine type
Engine number
Purchase date

For name plate see page 3/ image A/19.

For engine type and number see 3/ image B/6.

Please specify these data/information when ordering spare parts to avoid the wrong deliveries.

Use only Agria original spare parts!

Specifications, drawings and dimensions listed in these instructions are not binding. No requests (complaints) can be based on them.

We reserve the rights to change/improve these instructions.

This update includes:

- Instructions Manual
- The main machine
- Gearbox
- Toolkit

Symbols



Warning - Danger



Important information



Choke



Fuel



Oil



Operating elements (hoes)



Fast



Slow



Open (unlocked)



Closed (locked)



Visual check

Marking of parts

A

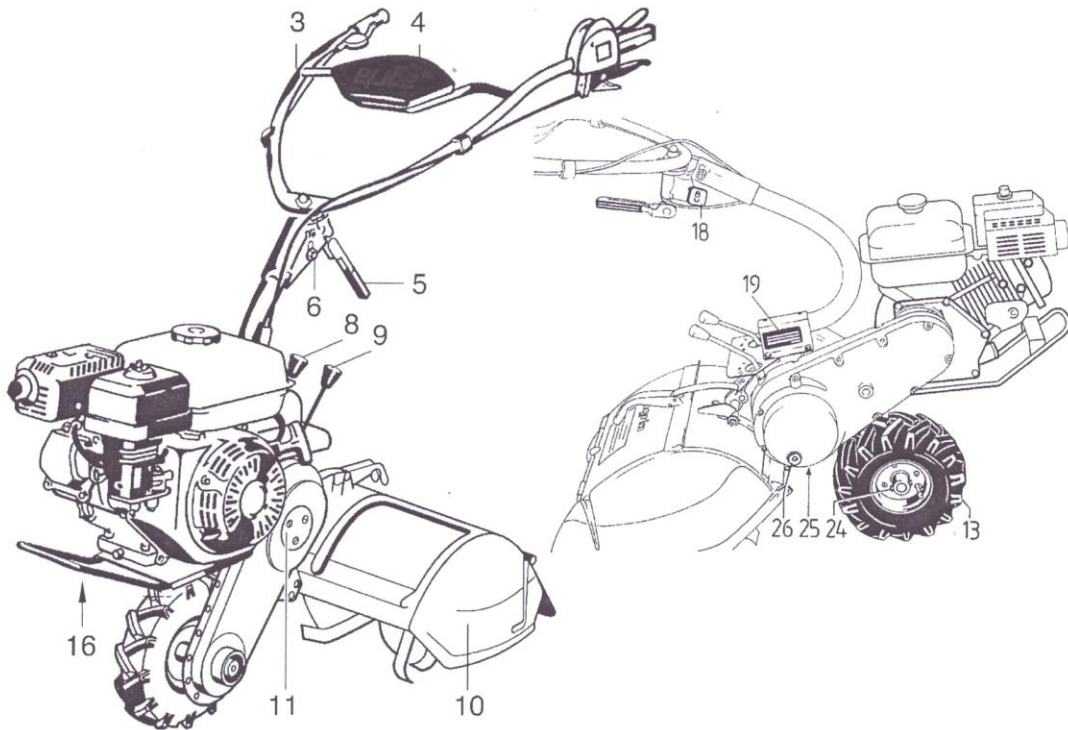

B

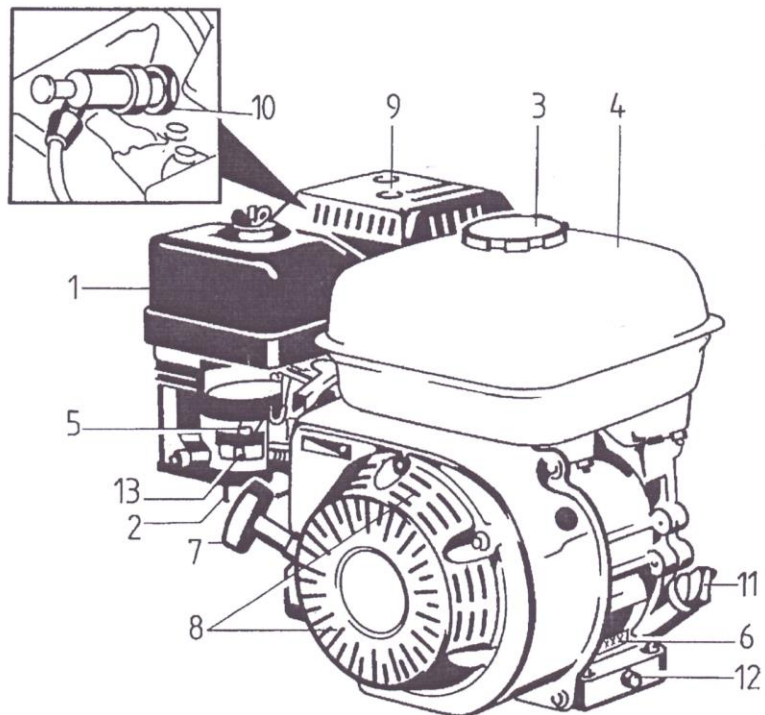

Marking of parts

Image A

3. Handlebar
4. Toolkit
5. Handlebar side adjustment lever
6. Hexagon screw (bolt) for handlebar height adjustment
8. Gear lever for adequate speed
9. Hoe-drive lever (tiller)
10. Tiller
11. Chain gear (transmission) housing cover
13. Driving wheel
16. Bearing
18. Square screw for handlebar height adjustment
19. Name plate / identification number
24. Hexagon screw (bolt) of the driving wheel
25. Mechanical transmission oil drain screw
26. Mechanical transmission oil filling and control screw

Image B

1. Air filter
2. Carburetor
3. Fuel tank cover (cap)
4. Fuel tank
5. Choke lever
6. Engine type and number
7. Starter handle
8. Air intake line
9. Exhaust with protection
10. Spark plug / spark plug cable
11. Engine oil level filling and controlling screw (cap)
12. Engine oil drain screw
13. Fuel valve

Contents

- General information 2	4. Starting and use	
(structure of delivery)	Starting the machine 21	
- Marking of parts 3,4	Starting the engine 22	
- Recommendations 6	Cultivating (tilling) 23	
Oil (lubricants), corrosion protection 6	Stopping (turning-off) the engine 25	
Fuel 6	Ridging 26	
Maintenance, Repair 6		
- Installation (assembly) instructions 7	5. Maintenance	
	Air cooling system 27	
1. Safety instructions 8-12	Mechanical gear 28	
	Clutch lever adjustment 30	
2. Specifications	Gear side adjustment 31	
Dimensions 13	General maintenance 32	
Motor hoes 13	Cleaning 32	
Tiller drive 13	Keeping (storage) 33	
Noise level 13		
Vibration level 13	6. Troubleshooting	
Engine 14	Scheme: Electric circuit 36	
Working on slopes 14	The maintenance plan 36	
	Oils (lubricants), varnishes, expendable parts 37	
3. Devices and operating elements	Inspection and maintenance 38	
Safety switch 16	Declaration of conformity 40	
Clutch 17		
Gear 17		
Handlebars 18		
Hoes (cutting blades) 19		
Drive wheels 20		
Adding weight – front 20		
Leaf remover 20		

Recommendations

Oil (lubricants), corrosion protection:

Use specified lubricants for engine and gear (see “Specifications”).

We recommend to use “**Bio-lubricating oils**” and “**Bio lubricating**” grease for open structures or nipples (as specified in the instructions).

To protect the machine and parts from corrosion use bio-processed oil, which can be applied either by brush or spray (do not apply on painted exterior parts).

Anti-corrosion agents are not harmful to the environment and are quickly degradable.

By using bio lubricating oils and lubricants, you contribute to preserving the environment, i.e. you do good to people, animals and plants.

Fuel

This engine runs on unleaded petrol.

Do not pour oil into petrol.

Drain the fuel tank if the machine will not be used longer than 30 days.

This is to prevent resin from depositing in the carburetor, fuel filter and tank; or add a fuel stabilizer to the fuel.

For more detailed instructions, see “Engine Storage and Keeping”.

Maintenance, Repair

The trained mechanics of FPM services perform professional maintenance and repair.

You should perform only basic maintenance and repair, only in case you have the adequate tools and knowledge of machines and internal combustion engines.

Do not hit the flywheel with a hard object or metal tools, as this may break and disrupt the work causing injury or damage. Use only adequate tools for tightening (pulling) of the flywheel.

Instructions for unpacking and assembling

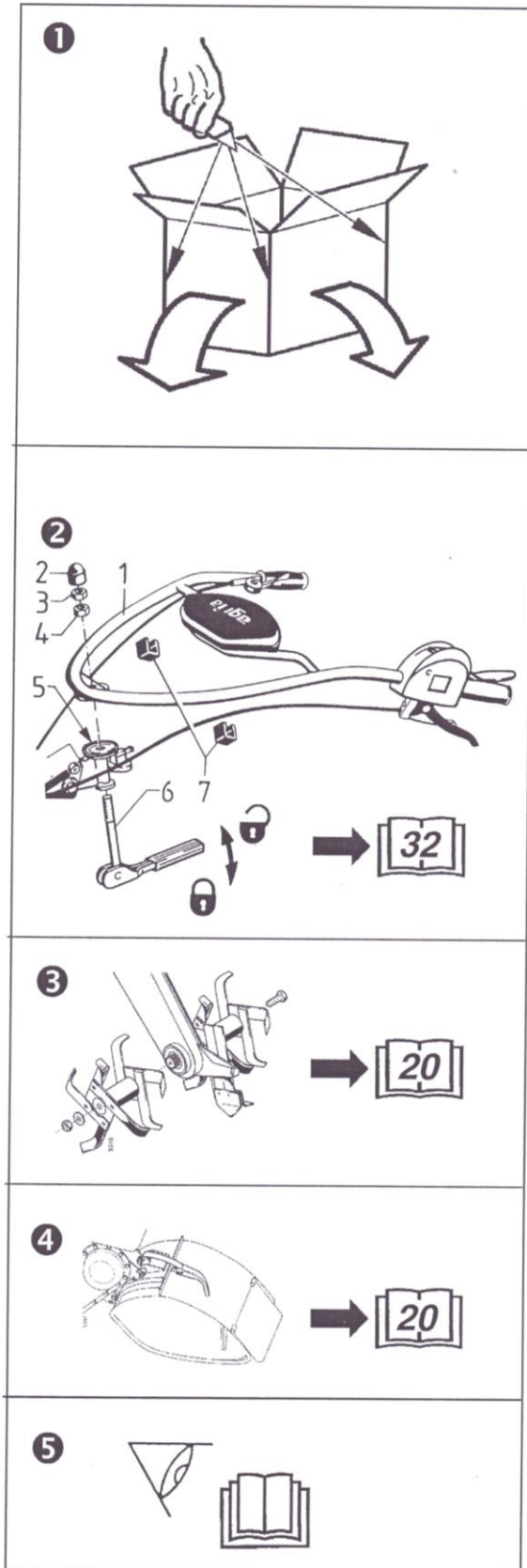

1. Open the top of cardboard box.

2. Adjust the handlebar.

3. Put (mount) the hoes and adjust the damper (limiter) - page 20.

4. Fit the protective cover (hood).

5. Make all steps to run the machine (see page 23) and see the instructions for Honda Engines.

1. Safety instructions

Before starting the engine, read carefully the operating instructions and remember:

WARNING



This symbol indicates all chapters important for your safety. Communicate the safety instructions to other users.

Proper Use

Motor hoes is constructed and designed for everyday use, for the tasks in forestry, gardening, as well as for the maintenance of grass and park areas.

Any use is considered improper. The manufacturer is not liable for damages resulting from improper use - it is the sole liability of the user.

Proper use of motor hoes implies compliance with the manufacturer's instructions on the use, maintenance and repair.

The factory bears no responsibility for any unauthorized changes to the motor hoes.

General instructions on safety and accident prevention

Basic rules:

One must observe the general rules on accident prevention, as well as all other general rules referring to security, safety at work and road traffic rules.

For the transportation of public roads, observe the traffic regulations.

Before use, always check the safe use of motor hoes. The motor hoes can be used, maintained and repaired only by persons who are well acquainted with the use and hazards of use.

Children under the age of 16 are strictly forbidden to handle the motor hoes.

Work only in good light and good visibility.

Wear tight clothing. Avoid loose clothing.

Wear sturdy shoes.

Remember the warning signs and instructions for safe use of motor hoes.

Observe them for your own safety.

When transporting the motor hoes by vehicle or trailer, be sure the engine is off.

Be careful with rotating parts - keep a safe distance.

1. Safety instructions

Beware of rotating elements. Before any work on them, make sure they are completely static.

Climbing the farm equipment (motor hoes) during operation is not allowed.

Farm equipment and its weight impact the driving, steering and braking characteristics of the motor hoes. Therefore, make sure that the steering and braking are well set. Adjust working speed to the working conditions.

High engine speed increases risk of accidents.

Work zone and Danger zone

The user is responsible for the persons who are in area of work of motor hoes.

Standing in the danger zone of the motor hoes is not permitted.

Check the motor hoes environment before starting it. Pay attention to children and animals.

Before starting to work, clean the area of foreign bodies, and during operation pay attention to the presence of foreign bodies and remove them in time.

When working in enclosed areas keep a safe distance to the fence in order to prevent damage to the blades (hoes).

Handling and Safety devices

Before use

Get informed about the devices and operating elements and their functions. Learn how to quickly and safely turn off the engine in case of emergency.

Make sure that all protective (safety) devices are mounted and positioned adequately to provide protection.

If there is no connector mounted, be sure to cover the output shaft with a protective cap.

Starting the engine

Do not start the engine in closed rooms. Carbon monoxide from the exhaust gas is highly toxic when inhaled.

Before you start the engine, set all operating elements in a neutral or idling position.

When starting the engine do not stand in front of the motor hoes or farm equipment.

Handling

Do not release the handlebars while the motor hoes is in the operation (work).

Do not adjust the handlebar during operation - **danger!**

1. Safety instructions

During any operation (manipulation) do not leave the handler position, particularly when the machine is in operation.

Climbing to the farm equipment during work or transport is not permitted.

If there is clogging of the tiller (equipment), shut down the engine and clean the tiller (equipment) with the appropriate tools.

If there is a damage to motor hoes or equipment, immediately turn off the engine and repair.

If there are problems with steering, stop immediately and turn off the motor hoes. Repair immediately.

To prevent slipping of the motor hoes on slopes, you need an assistant who will, by using a rope or rod, hold the machine. This person must be at the higher place than the machine and at a safe distance from the operating elements.

If possible, always work horizontally to the slope.

End of work

Never leave the motor hoes unsecured with the engine running.

Before leaving the machine, turn off the engine and then turn off the fuel tap.

Secure the motor hoes against unauthorized use - remove the spark plug cable.

Additional equipment

Mount additional equipment only when the engine and the drive are off. Always use appropriate tools and protective gloves when changing equipment or parts.

For assembly and disassembly, use the support devices to bring the motor hoes in a convenient and stable position.

Secure the motor hoes and equipment against rolling (use the supporters).

Beware of injuries when mounting equipment, be very careful.

Mount the equipment as specified in the instructions and connect them with the motor hoes only at the designated points.

Secure the motor hoes and equipment from unauthorized use and rolling when you leave the machine.

Additional equipment – tiller

Set the tiller hood so that only those parts (hoes) tilling the soil are not covered.

When tilling (cultivating), make sure that the slider is set up correctly.

1. Safety instructions

Maintenance

Never clean or repair the machine when the engine is running.

Before working on the engine remove the spark plug cables.

Check all protectors on the tool and, if necessary, replace them.

Replace the damaged blades (hoes).
Always wear the protective gloves and use the adequate tool when replacing the hoes.
Do not weld, grind and punch either the base machine or security-related parts (such as connection device).

Always clean the motor hoes and connections in order to avoid the risk of fire.

Check whether all the nuts and bolts are tightened enough and tighten them if necessary.

Check all the changeable parts that have been damaged or worn, whether they are properly installed and tightened.

Use only original spare parts manufactured by FPM Agromehanika Boljevac.

All other commercial parts must comply with the quality and technical requirements specified by FPM Agromehanika Boljevac.

Garaging (storage)

It is not allowed to store the motor hoes in rooms with open fire.

Never leave the motor hoes with fuel in the tank in closed rooms.

Fuel vapors are dangerous.

Engine, fuel, oil

Do not let the engine running in a closed room. There is a great danger of carbon monoxide poisoning!

Be careful when working with fuel. There is a high risk of fire!

Never refuel near open flames, sparks or hot engine parts. Do not refuel in closed rooms. Do not smoke when refueling!

Refuel only when the engine is cold and turned off.

Use a suitable funnel to avoid fuel spilling.

If you spill fuel, move the motor hoes away from the spilled fuel, and then start the engine.

Be sure that the fuel is of adequate quality.

Store fuel only in adequate containers.

1. Safety instructions

Explanation of warning signs

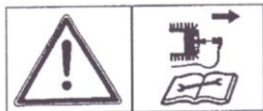

Before any work on the cleaning, maintenance or repair, turn off the engine and remove the spark plug cable.



When the engine is running, keep a safe distance from moving parts (hoes) of the motor hoes.



Do not work without protective cover. Before starting the engine, set the cover in an appropriate manner.



Do not touch the moving parts of the machine. Wait until they completely stop moving.



Keep a safe distance with the engine running.

Signs



When working with the machine, wear ear protection (anti-noise headphones).



Wear protective gloves.

2. Specification

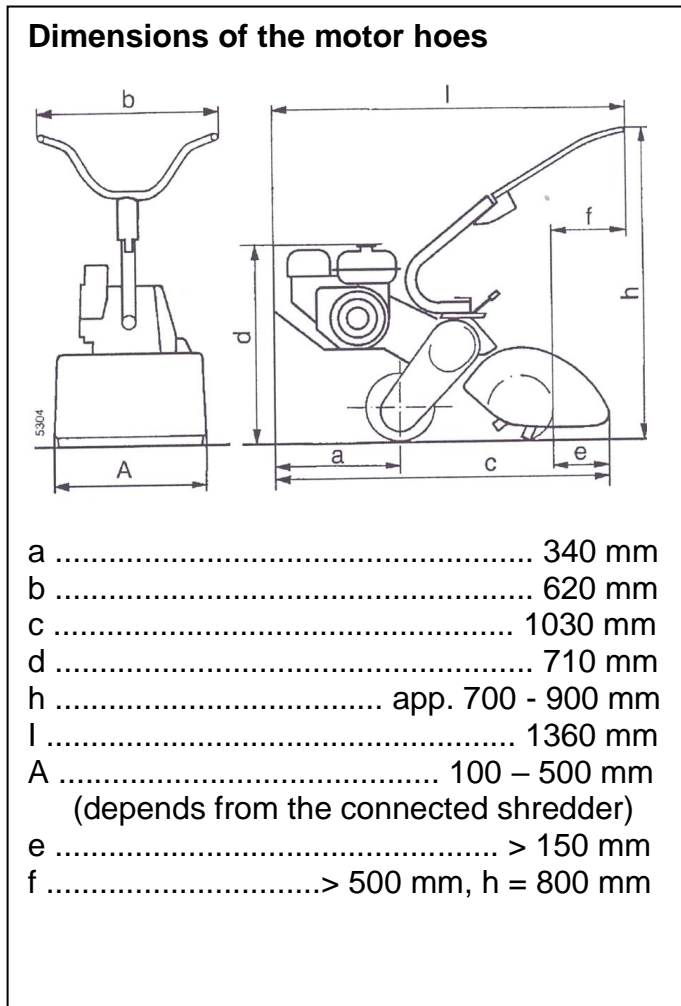

Vibration level

At the handlebar $a_{hw}=5,9 \text{ m/s}^2$
 (in compliance with EN 709 and EN 1033)

Noise level

Noise in the ear of the operator 83 dB
 (in compliance with EN 709)

Weight app. 51 kg

Type FPM 512

Tires 3.004

Tire pressure 0,8 bar

Clutch multiple in oil

Gearbox 2 speed mechanical gearbox wheel and rotary tiller PTO achieved by means of two special chains.

Oil quantity app. 0,6 l
 Gearbox oil BP TFJD - GL4

Lubricant quantity:

In the wheel driving chain housing
 app. 150 g

In the tiller driving chain housing app.
 150 g liquid lubricant (e.g. BP LS-EP00)

Movement speed:

first gear 2,7 km/h

second gear 4,8 km/h

Tiller movement speed:

first gear 196 min^{-1}

second gear 350 min^{-1}

Tiller working width: 10-50 cm

depends of the connecting tiller version

Additional equipment:

..... tiller 10-50 cm

..... ridger 2152 011

..... front weight (ballast) 3128 011

..... leaf remover 2130 031

2. Specification

Engine

Manufacturer Honda
..... Kipor

Type Honda - GX160 K1 QPU
..... Kipor - KG 200

Engine type air-cooled
fan, single-cylinder, four-stroke, gasoline

Piston diameter 68 mm

Piston stroke Honda - 45 mm
..... Kipor - 54 mm

Working capacity..... Honda - 163 ccm
..... Kipor - 196 ccm

Compression 8.5 : 1

Power output 4,0 kW at 3600 min⁻¹

Maximum torque
..... 10,8 Nm at 2500 min⁻¹

Spark plugs BOSCH WR
..... NGK BPR6 ES
Spark plug electrode gap..... 0,7-0,8 mm

Ignition system contactless,
magnetic electronic ignition,
preset ignition point, radio
interference eliminated in
compliance with VD 0879

Valve closing (cold engine)

At inlet 0.15 mm ± 0.02 mm

At outlet 0.20 mm ± 0.02 mm

Start manual, by the pull rope,
with the mechanism -
decompression device.

Tank capacity 3,6 l

Fuel min. 850 octanes
(See recommendations for fuel
in this Manual)

Air filter dry

Carburetor with relief valve

Mixture control screw opens with
about 2 : 1/8 turns

Normal speed (RPM) 3600 min⁻¹

Max speed (RPM) 3850 min⁻¹

Idling RPM 125 – 1600 min⁻¹

Engine oil:

Capacity app. 0,6 l
High-detergent oils SAE 10 W-40 SG,
SF or of higher quality

Working on slopes: < 20° (44%)
When the oil is at the maximum - to
the upper line.

3. Devices and operating elements

Motor hoes is adapted for common use in agriculture, gardening and forestry, as well as for maintenance of parks.

The following additional equipment is available:

- tiller 10 - 50 cm
- ridger
- front weight
- leaf remover

Engine

Four-stroke engine running at the usual fuel (see Fuel Recommendations on page 6).

During the first 20 hours of exploitation, the engine should not be burdened to the maximum. Even after the “developing” period, never work with a speed higher than necessary.

 High speed of engine damages each engine and significantly affects its durability. This applies particularly to work that does not require full engine load. Any over-speed manifested in the noise of the engine may momentarily damage the engine.

Cooling system

The cooling system is by fan. Therefore, it is necessary to keep clean starter grid and cooling fins of the engine.

Idle speed

Set the idle gas appropriately. The engine should work mildly (slowly) without turning-off.

Air filter

The air filter filters the air entering the engine. The outlet filter reduces harmful exhaust emissions.

Ignition system

The engine is equipped with a contactless electronic ignition system, whose maintenance is minimal.

Necessary changes should be performed by experts in electronics, or address the FPM's service.

3. Devices and operating elements

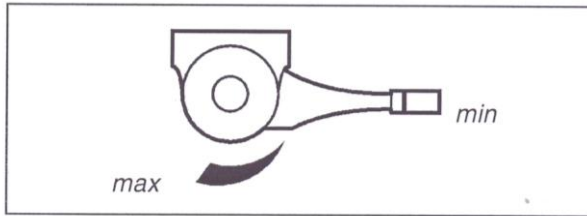

Speed control lever (gas lever).

Gas handle placed on the handlebar serves for adjusting of the speed from the minimum = idle to the maximum = full gas.

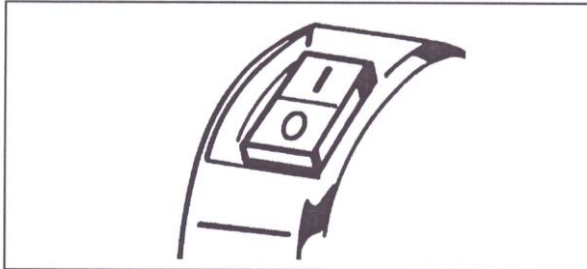

Engine switch off button

The machine is equipped with an electric power switch. By pressing the switch the engine is turned off.

Position "I" = operation.

Position "0" = the engine turned off

i Engine switch off button is also used for emergency shutdown in case of emergency. For fast shutdown press the switch to the position "0".

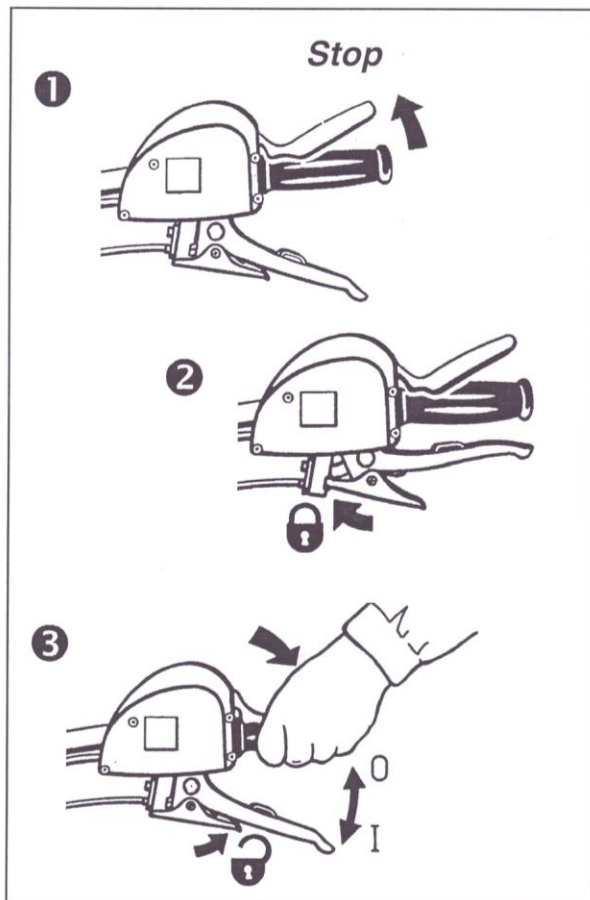

Safety lever

The machine is equipped with the safety lever.

1 Position STOP: When the lever is free (released), the ignition system is stopped (engine off).

Keep in mind - the engine continues to run due to centrifugal force.

2 Position START: To start the engine and for short breaks in the work, pull the clutch lever (C15) and secure it by the interlock lever.

3 Operating position: During work, keep the safety lever pressed (C14).



Do not tie the safety lever!

i Safety lever is also used for emergency shutdown of the engine. In case of emergency, release the handle to quickly turn off the engine. The lever automatically goes to the "STOP" position.

3. Devices and operating elements

Clutch

By pressing the clutch lever transmission is separated from the engine drive ("0").

By pressing, the lever can be blocked with the interlock (pawl) (C16)

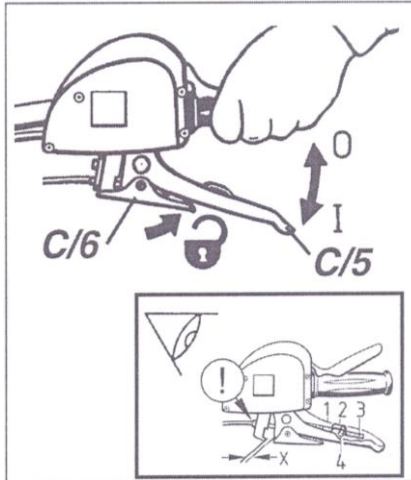

The clutch is functional when you release the clutch lever and when the pawl is unlocked.

To avoid the clutch slippage during work, its running is set on the handle at the factory.

Maintenance - page 32.

After the first few hours of use the clutch running should be checked and adjusted if necessary.

Maintenance - page 32.

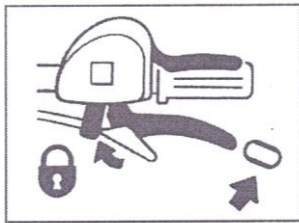

Always park the machine with clutch lever down (blocked by pawl).

Otherwise, you may encounter problems with the clutch due to deformity of the V-belt (wedge)

Gearbox



Change speed when the clutch is pressed. Move the gear lever only by your hands.

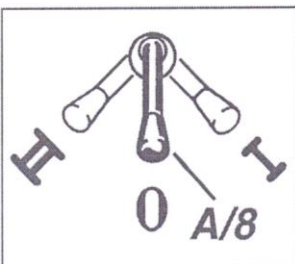

Gears

The speed of wheel movement and tiller is determined by the gear lever (A18)

0 = neutral (idle)

I = first gear

II = second gear

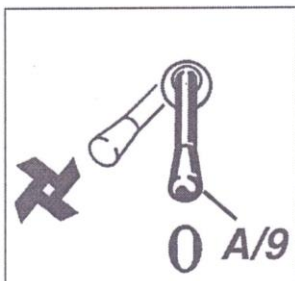

Tiller drive

Tiller drive is secondary on the two-stage mechanical gearbox.

This means that the tiller drive can be operational only when the first or second gear is active.

Tiller drive is activated / deactivated by the gear lever (A/9).

3. Devices and operating elements

Handlebars

Height adjustment of the handlebar

- Unscrew hexagonal screw (2) and release the rectangular part of tightening. Pull the plate from the steering column.
- Adjust the steering wheel to the desired height and place it in a position corresponding to the hole on the plate of the steering column.
- Thread the hexagonal screw through the opening and tighten the square part of tightening. (Make sure that square tooth of the belt lies into the right opening on the plate of the steering column).

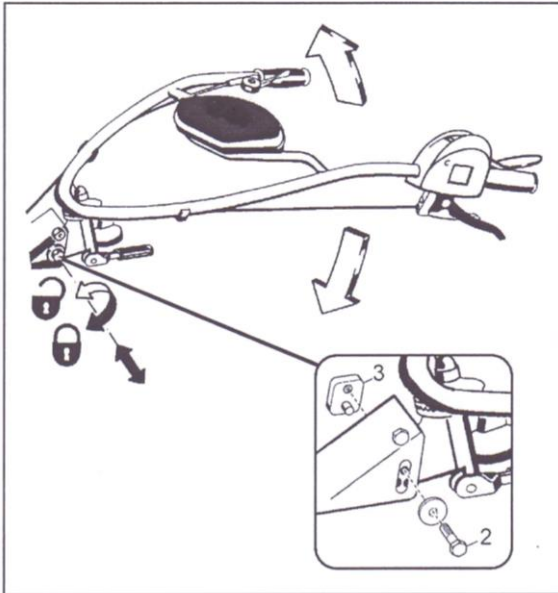

Side adjustment of the handlebar

- Pull the tense lever upward (1), and be sure that the pinions are tightly fit.
- Push the tense lever down.

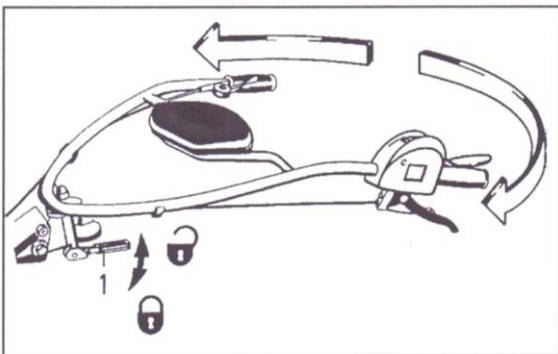

3. Devices and operating elements

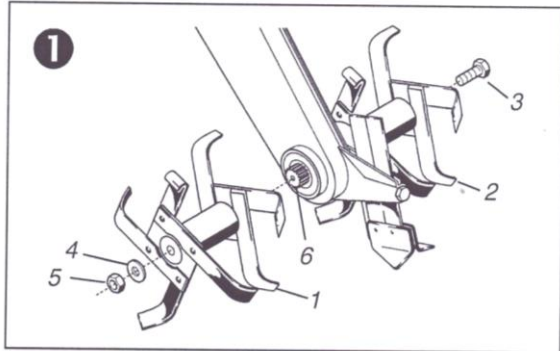

Parts of the tiller

① Mounting of tiller parts (hoes)



Wear safety gloves

- Mount the hoes (1+2) on the tiller shaft (6). The sharpened hoes sides should be turned to the direction of rotation (forward). Mount the hoes so that they are not parallel.
- Insert the screw from right to left, put the washer and tighten with hexagonal nut (5).

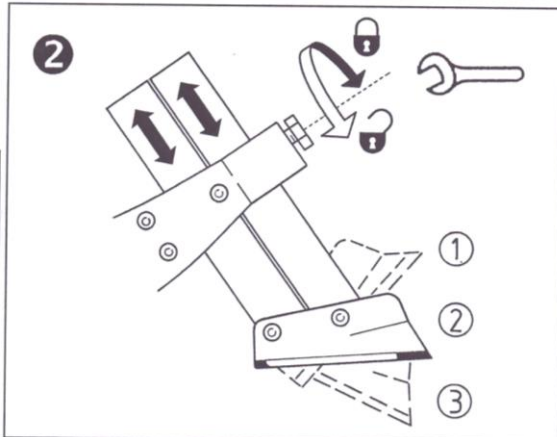

② Tiller slider

- ① - For difficult grounds and rough tilling
- ② - For “easy” grounds and fine tilling
- ③ - For sandy grounds



Do not till without slider.

The protective cover (hood)

③ Mounting of protective cover

- Fit the protective cover with the carriers and hook
- Hook the end of the hook and pull the lever.



Do not till without protective cover.

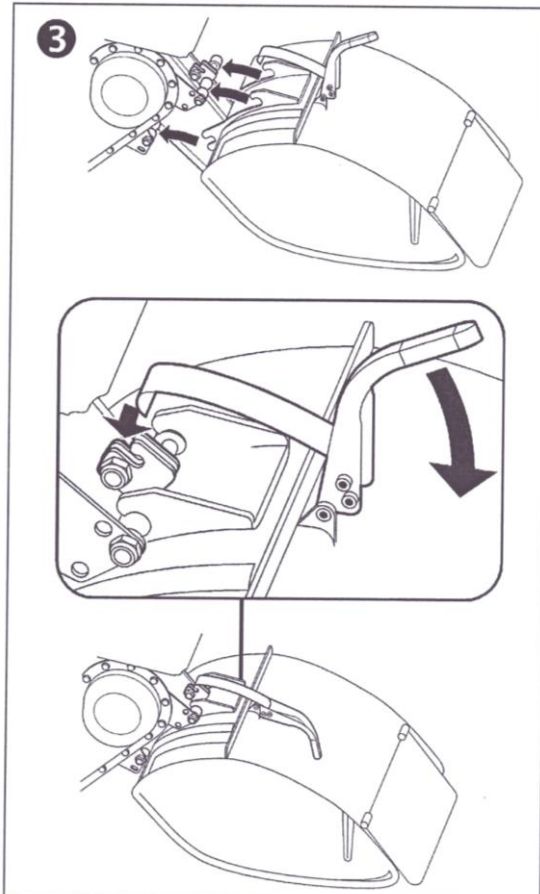

3. Devices and operating elements

Drive wheel

Motor hoes has a centrally positioned rubber drive wheel as standard equipment.

Mounting of drive wheel

- Put the wheel shaft in place. Push from the left to the right (in the direction of movement)
- Put the drive wheel on the shaft end.
- Secure with hexagonal screw and nut, by putting the screw through the opening in the middle of the wheel shaft.

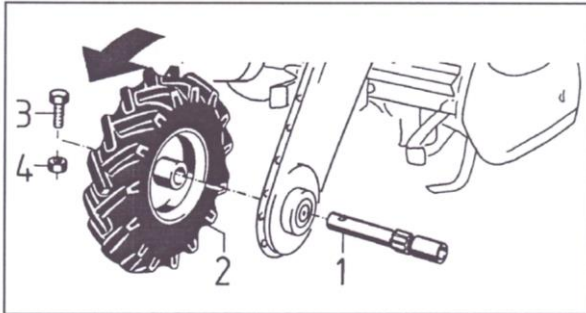

-  Mount the wheel with the patterns turned to the direction of movement (forward)

Front weight

-  **Mount the weight only when the engine is cold - danger of burns.**

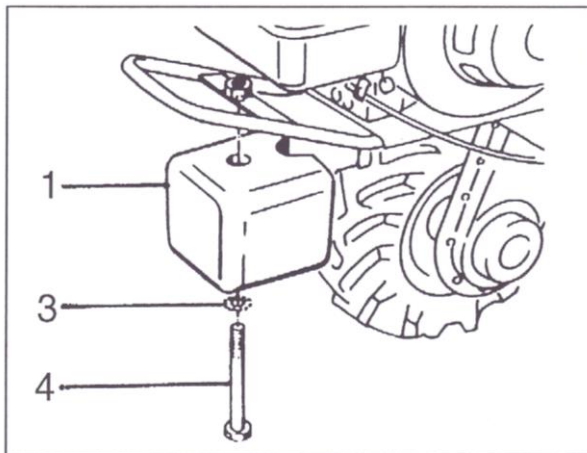

Mounting of front weight

Mount the front weight on the engine bearing and fasten with hexagonal screw and toothed washer.

4. Starting and use

Start

Remember that the durability and safety of use of the engine is significantly affected by its working out. Always wait a few minutes for the engine to warm up and do not use the maximum gas at the beginning.

Remember: during the first **20** hours of use (working out period) do not use the full power of the engine.

 **Note:** Due to transport reasons, the engine is not filled with oil.

Before you use the engine for the first time, pour the oil (see Honda operating instructions)!



 **Check and maintain clean air filters and use pure fuel. Use only tested fuel.**

Use only fresh, pure fuel (not older than 3 months) and approved metal vessels for storage purchased at the authorized stores.

It is not allowed to use packaging that is not intended for fuel.

When starting for the first time or after a long period of inactivity, fill the tank to the top to avoid problems at starting.

 **Be careful when dealing with**

 **Fuel is flammable and can explode under certain conditions**

- Do not refuel in enclosed spaces.

- Before each refueling, stop the engine and let it cool.

- Never pour fuel near an open flame, embers, sparks or heated engine parts.

- Do not smoke during refueling!

- Do not spill fuel, use a suitable funnel.

Do not overload the tank, leave 5 mm to the maximum, since the fuel expands

4. Starting and use

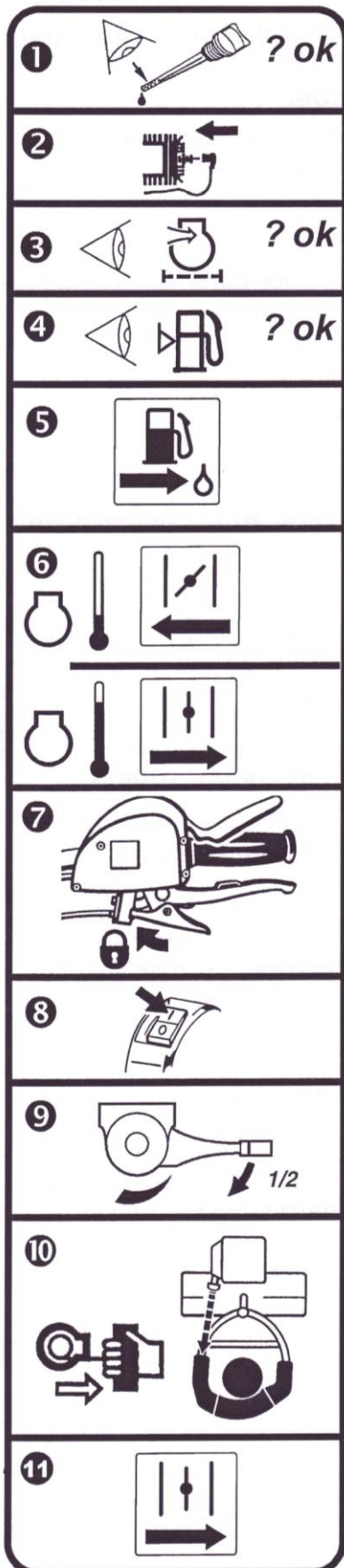

Starting the engine

⚠ Do not start the engine in closed rooms!
The exhaust gases contain carbon monoxide which is harmful when inhaled.

👁 Is the protection mounted?
👁 Is the tiller well connected?

- 1** Check the engine oil level.
- 2** Connect the cable to the spark plug.
- 3** Is the air filter clean?
- 4** Is there enough fuel in the tank?
- 5** Open fuel supply (tap)
- 6** Cold engine:
Move the choke lever to position “CHOKE” (“sava”).

Heated engine:
Do not use “sava” (work position).
- 7** Set the clutch lever and safety lever to the start position.
- 8** Turn the switch off switch to position “I”.
- 9** Move the gas handle to the mid position (between the idle and max. gas).
- 10** Start the engine from the position outside the danger zone.

- Take the starting rope and slowly pull the rope until you feel resistance. Then pull the rope quickly and strongly along its length. Once the engine starts release the rope slowly. Do not suddenly release it.
- 11** “Sava” in the work position.

4. Starting and use

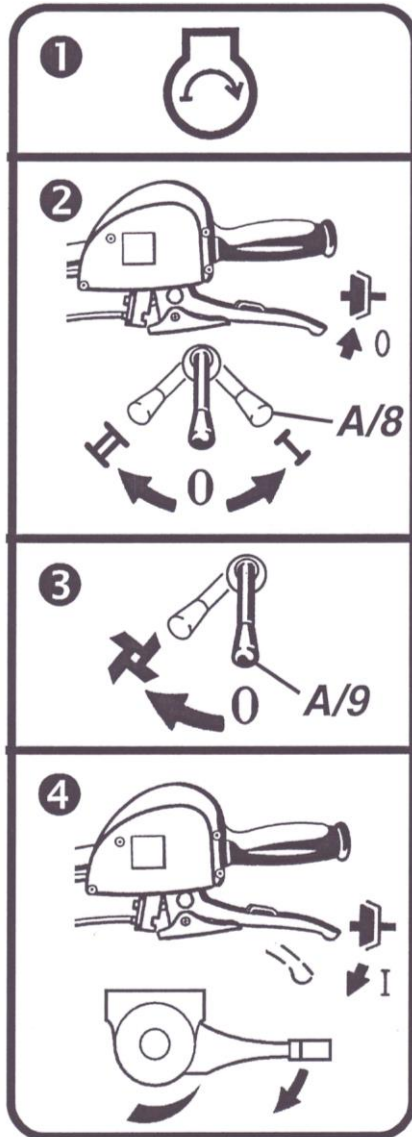

Cultivating (tilling)

❶ Start the engine - page 24.



Check the safety lever - use the machine only if the safety lever works properly!

Wear ear protection and sturdy shoes.

- ❷ Press the clutch lever.
- Switch the handlebar (A18)
- For rough cultivating
- Select the lower speed "I"
- For fine cultivating
- Select the higher speed "II"

❸ Switch the tiller drive lever to the position - cultivating (tilling).

❹ Slowly release the clutch lever, while adding gas - motor hoes moves forward and the tiller starts working.



Never leave the operator position while the machine is in operation.

While working with the motor hoes, particularly in rotation, the user must keep a safe distance as required by the handlebars.

Do not clean parts of the tiller while the engine is running. Turn off the engine and remove the spark plug cable.

If congestion occurs, turn off the engine and clean the connection with the appropriate tool (wooden stick).

4. Starting and use

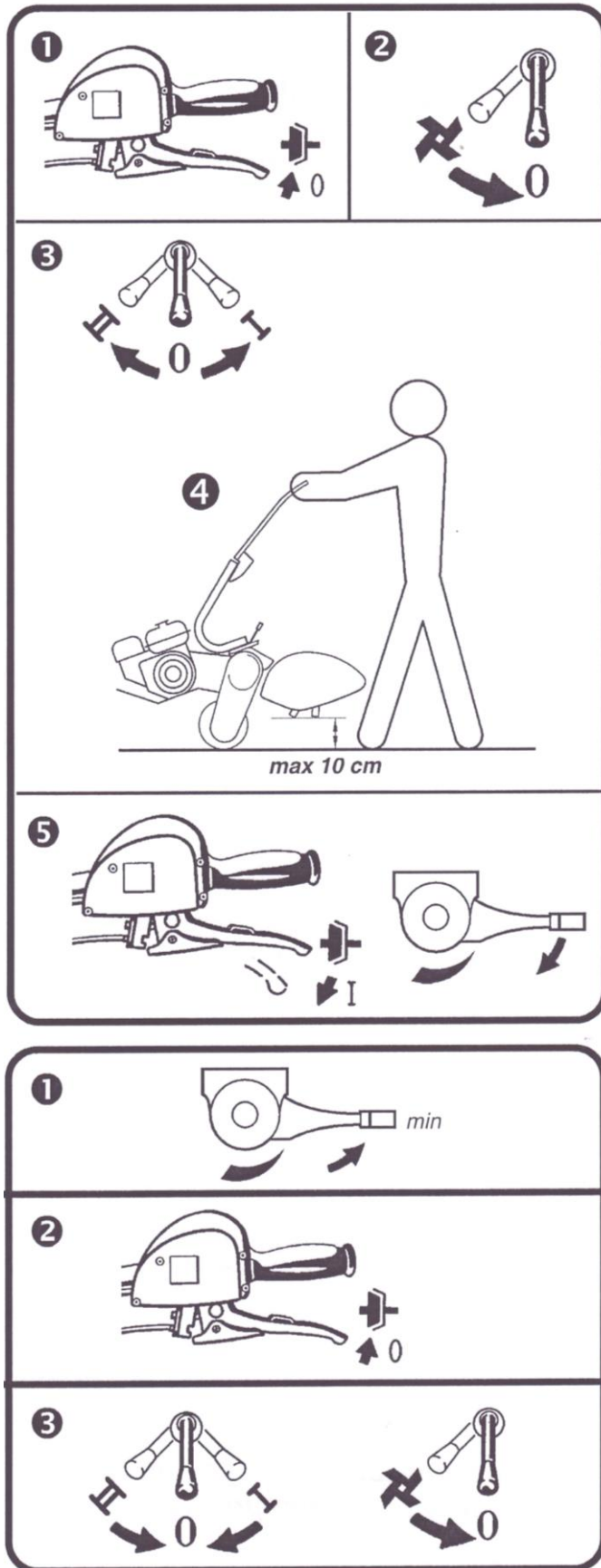

Turning the motor hoes

- 1 Press the clutch lever
- 2 Turn off the tiller drive, position "0".
- 3 Switch the gear lever to the position "I" or "II".
- 4 Gently lift the rear part of the motor hoes by means of the handlebars, so that the parts of the tiller do not touch the ground, maximum of 10 cm from the ground.

- 5 Slowly release the clutch lever while slightly pressing the gas lever - motor hoes moves forward, while the tiller does not work.

End of cultivating

- 1 Set the gas lever to idle position (min)
- 2 Press the clutch lever and hold it.
- 3 Move the gear lever and tiller drive to the position "0"

4. Starting and use

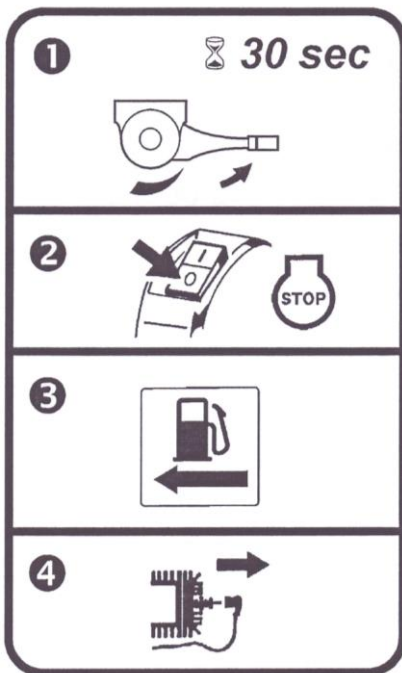

Turning-off the engine

- ➊ Shift the gas lever to the idle position (idle), and let the engine work in that manner for about 30 sec.
- ➋ Shift the engine power switch to the position "0"
- ➌ Close the fuel tap.
- ➍ Remove the cable from the spark plugs - protection against unauthorized use



Wait for the engine to cool before parking the motor hoes in a closed room.



Do not shift the choke lever to position CHOKE when you turn off the engine - FIRE HAZARD!



When you leave the machine unused for a longer period of time, do not turn the engine by the shutdown switch. Instead, close the fuel tap and run the engine until there is fuel. In this way, the carburetor is emptied and the resin residue is avoided.

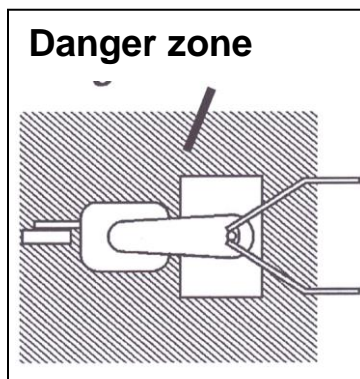

Danger zone

Keep a safe distance from the machine during starting and use!

4. Starting and use

Ridging with ridgers

Required accessories

Tiller
..... options 28,32; 38 cm

Front weight
..... article No. 3128 011

Ridger with protective cover
..... article No. 2152 011

Mounting of the ridger

- Remove the cover
- Place a special protective cover (1) for ridging
- Put the ridger handle (2) to the opening in the cover and tighten it with hexagon screw (4).

- Adjust the angle of the ridgers with hexagonal screw.

The ridging depth depends on the angle - the greater angle of the ridger backwards, the higher (deeper) operating depth

- Put the front weight

Ridging

- Start the motor hoes as described in the "Cultivating" ("tilling") Chapter.

- After a few meters of cultivation, adjust the desired ridging depth. For this purpose, set the angle and height (5) of the ridgers by using hexagonal screw (3) and slider (5).

- Set the desired ridging width by adjusting the ridger boards and tightening the screw (6).

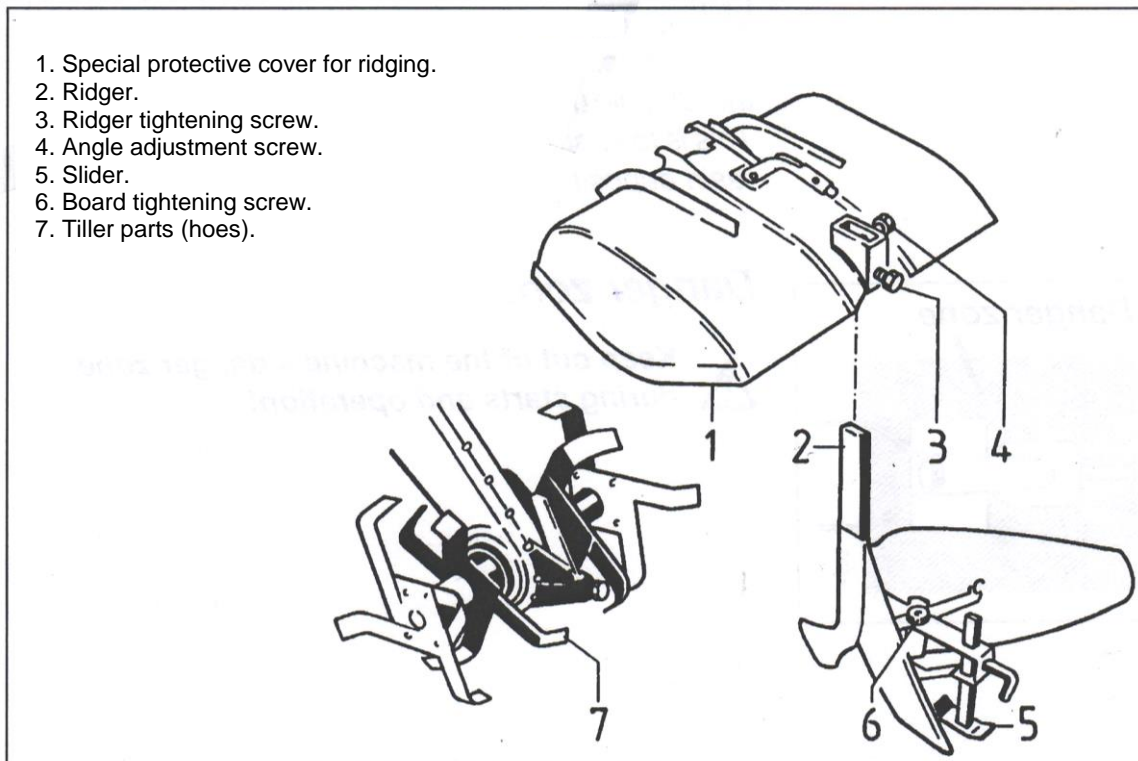

5. Maintenance

In addition to already provided instructions for use of motor hoes, it is also very important that you observe the following instructions for maintenance

! Attention: Perform all maintenance work when the engine is switched off.

Always remove the spark plug cable to prevent accidental engine ignition.

Always wear protective gloves when working with tiller parts (hoes).

The machine will be reliable to use, if properly maintained. After each use, clean the machine, particularly the tiller parts (hoes).

i Please observe only those actions that are described herein and that are needed to use motor hoes. All other information on the engine can be found in the attached Instructions on the use of engine!

Cleaning of the air-cooling system grid

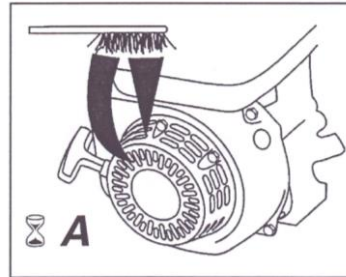

After longer use, dirt may clog (choke) the cooling system. To avoid overheating and damage to the engine, regularly clean the air-cooling system grid (B18).

Check it before each use!

Air-cooling system

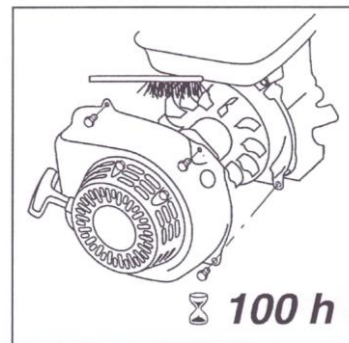

Clean the inside and the fins and the cooling system at least every 100 hours of use (even earlier) if the work is performed under very dusty (dirty) conditions).

Air-cooling system

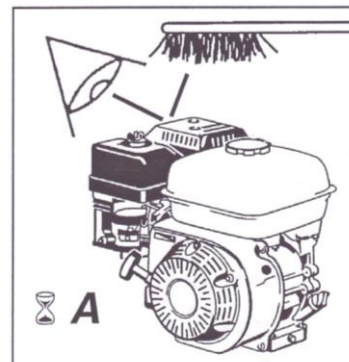

Regularly clean the area around the exhaust (B19). Remove grass, dirt and flammable deposits.



- Fire hazard!

Always check before use.

5. Maintenance

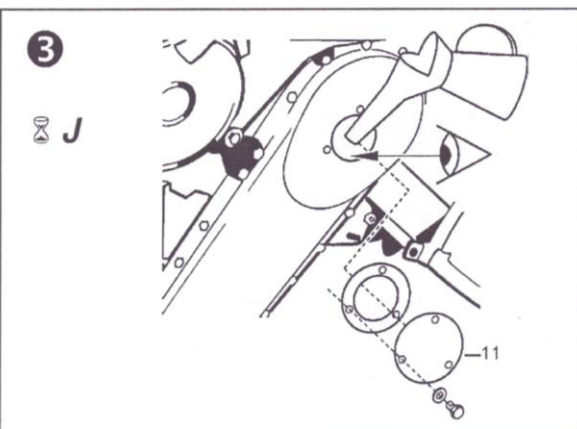
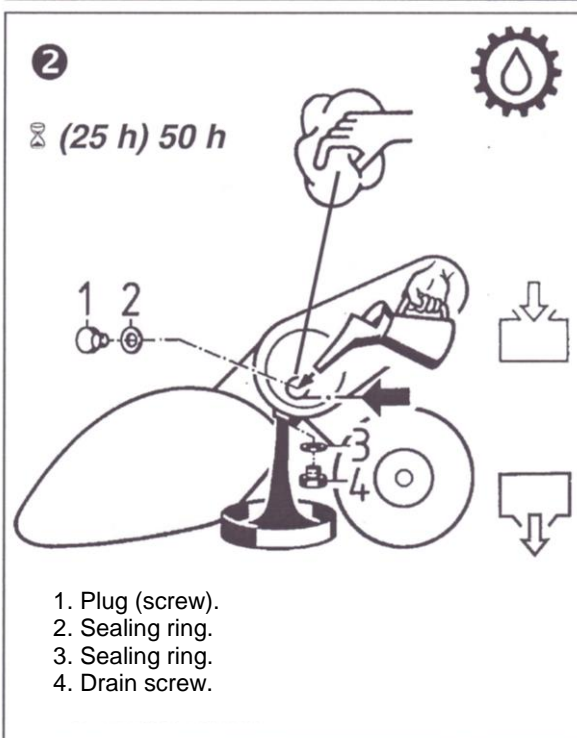
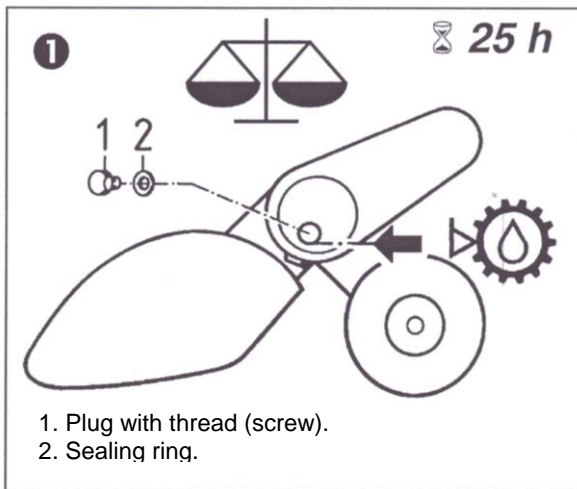

Turning motor hoes

❶ Check the oil level in the gearbox before running the machine and after every 25 hours. When the machine is parked on level ground, the oil level must be visible to the screw thread. Add oil if necessary.

❷ Change the oil in the gearbox after the first 25 hours of operation and then after every 50 hours. Open the inlet for adding oil and unscrew the drain screw, clean the surrounding areas so that no dirt can get into the gearbox.

For oil quality and quantity see “Specifications”.

Wheel and tiller drive

The wheel and tiller drives are pre-lubricated with 150 gr. lubricant (liquid).

If there are no visible traces of grease on the housing and seals, grease is not required.

❸ Lubricant check

- open the cap on the housing (A/11)
- turn the tiller wheel and shaft 6 times. If both chains are greased (visual check) lubrication is correct. Add liquid grease if needed.

Remember: There are two chains in the housing!

Drive wheel



Periodically check the pressure in the wheel (0,8 bar).

5. Maintenance

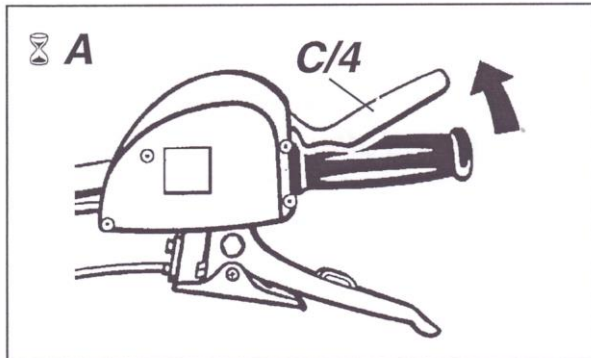

Safety handle

Always check the safety lever before work and during each maintenance work.

- When the clutch is engaged and safety lever released (turned up), the engine must automatically stop.
- Check electrical cables and connectors and replace them if necessary.

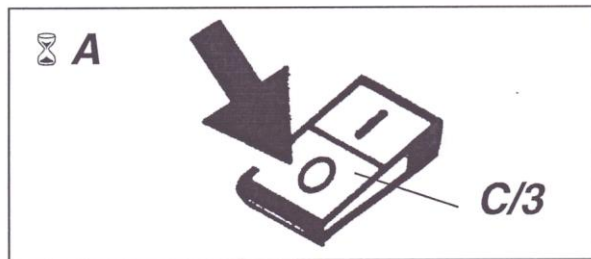

Engine turn off switch

During maintenance always check engine turn off switch.

If the switch is in position "0", the engine stop.

Check electrical cables and connectors and replace them if necessary.

5. Maintenance

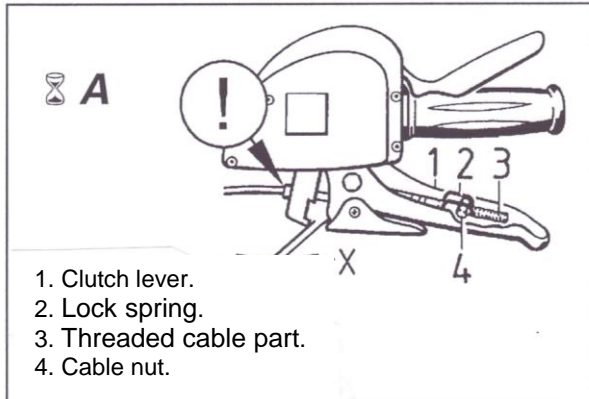

Clutch lever

During each use, check the movement (gap) of the lever and adjust it if necessary (particularly during the working out period after starting the engine and after changing parts of the clutch).

Clutch

X = 3 – 5 mm (with clutch)

! =

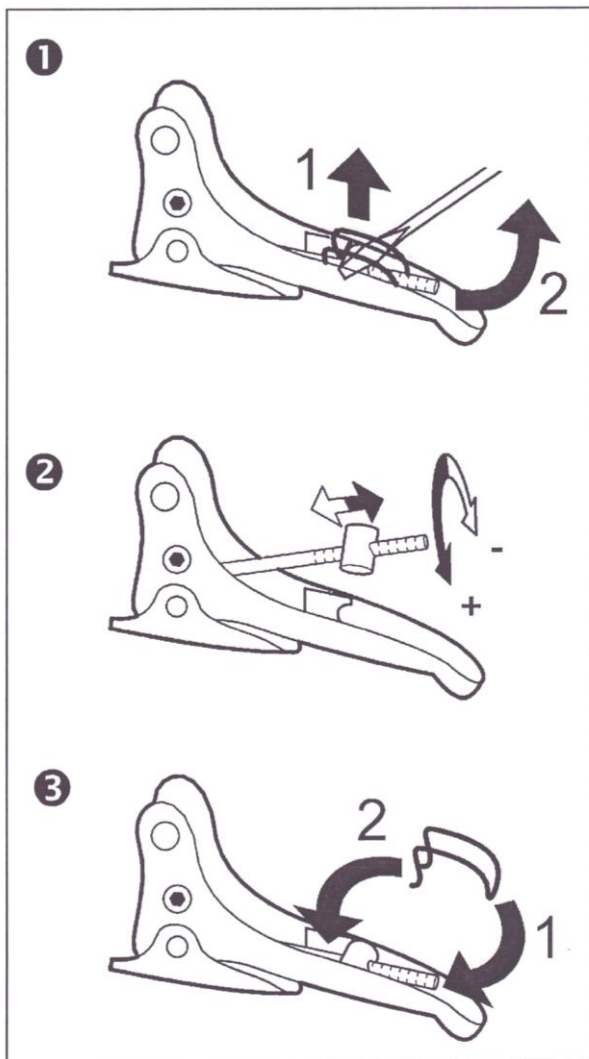

Adjusting

1 Remove the lock spring (2) and lift the threaded part of the cable from slot on the clutch lever.

2 Set the cable nuts cable so that that gap is 3 - 5 mm.

3 Put the threaded part of the cable back into the handle slot and also put the lock lever back (2).

5. Maintenance

Clamping lever for side adjustment of the handlebar

If the clamping lever (1) is pressed down and steering wheel is not fixed well enough, make the adjustment.

Adjustment

- Remove the nut cap.
- Release the upper nut (3) approximately two turns.
- Release the clamping lever (1) = push it upward while pressing the steering wheel to the locking plate.
- Turn the clamping lever to the left while the lower nut is released from the bearing.
- Screw the nut 1/6 to 5/6 turns clockwise, as necessary.
- Put the nut back into place, turn the clamping lever to the center position and tighten.
- Check the tension (tightness). If it is still not good, repeat the adjustment.
- Tighten the upper nut (3) and put the nut cap (4).

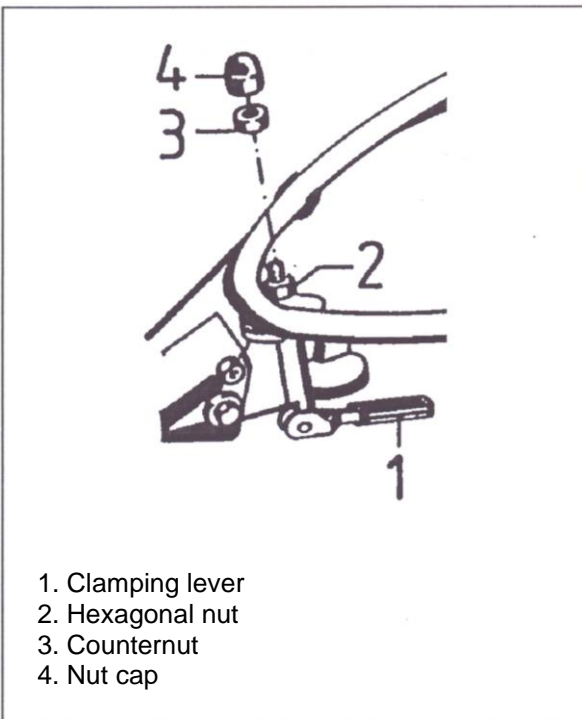

5. Maintenance

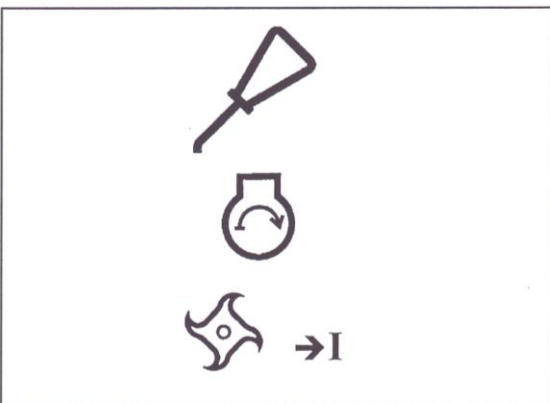
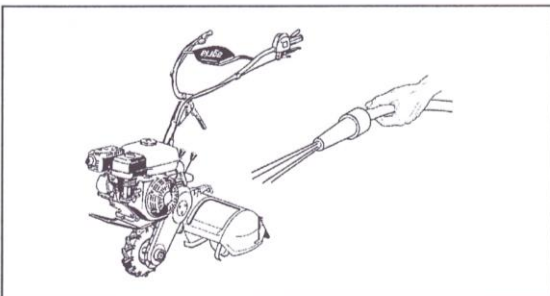
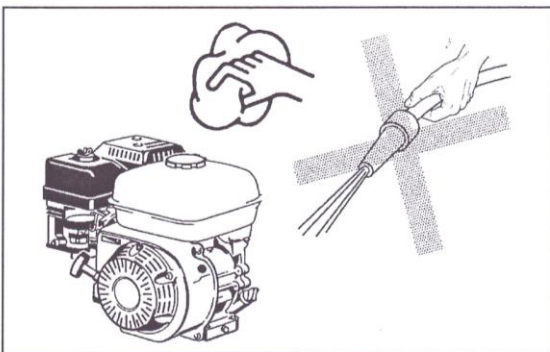
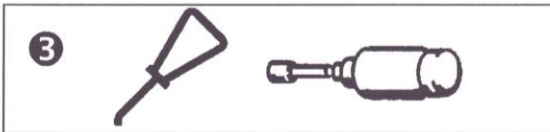
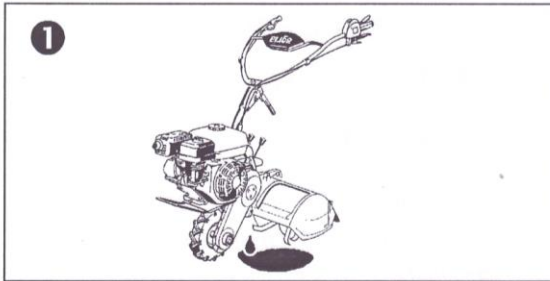

General

- 1 Check if there is leaking of oil or fuel, and if necessary, fix it.
- 2 Regularly check the tightness of nuts and bolts: re-tighten if necessary.
- 3 Once a year, after cleaning, carefully lubricate all moving and sliding parts (e.g. gas lever, lever bearing, etc.) with bio grease or lubrication oil.

Cleaning

Engine

Clean engine only with a cloth. Avoid spraying by high pressure water jet (compressor), since water can enter the ignition system and fuel which can cause malfunctions.

Machine

After each use, immediately clean the tiller parts and protective cover. Lubricate all moving parts with bio grease or bio lubrication oil.

After cleaning the machine with pressured water immediately lubricate the points that are to be lubricated and let the machine run briefly to remove excess water.

Apply a layer of bio grease around all the bearings in order to prevent the penetration of water, vegetable juices or dust.

5. Maintenance

Keeping (storage)

For longer periods of inactivity prepare the machine for storage.

Do the following:

a) Clean thoroughly

Paint chassis if necessary.

b) Spray all shiny parts and tiller components with bio lubrication oil.

c) Engine preservation (keeping) Engine

- Drain the fuel tank or add fuel stabilizer.
- Refer to the attached instructions. Let the engine run for about 1 minute.
- Change the engine oil.
- Place a teaspoon of oil into the spark plug bearing (0.03 lit.). Slowly start the engine (probably through the rope).
- Set the piston so that the valves remain in the closed position (pull the starter rope until you feel tension).
- Slowly start the engine every 2-3 weeks (spark plug cables removed). Then adjust the pistons again.

d) Drive wheel

Support the drive wheel so that the tire has no contact with the ground. The tire decays first if left standing under load and unsupported.

e) Clutch

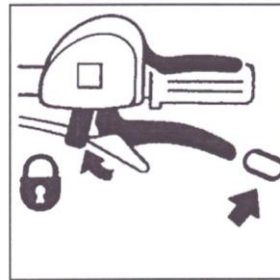

Always park the machine with clutch lever down (position "0" - locked pawl). Otherwise, you may encounter problems with the clutch due to corrosion.

f) Keeping



Due to the hazard of corrosion do not park (leave) the machine:
- In wet rooms
- In rooms with stored fertilizer.
- In stables.

g) Protect the machine

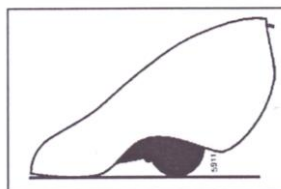

Protect with canvas or similar cover.

6. Troubleshooting

Read carefully the safety instructions! Leave all serious repairs on the machine or engine to FPM service department. They have the adequate tools. Inadequate repairs can only increase the damage.

Problem	Possible cause	Take action (repair)	Page
The engine will not start	<ul style="list-style-type: none"> - The spark plug cable is not connected - "Sava" is not in "sava" (CHOKE) position - Fuel tank empty or with little fuel - Clogged fuel supply - Poor spark plug - Too much fuel in the engine (flooded engine) - Air penetrates into the loose carburetor and the intake duct 	<ul style="list-style-type: none"> - Connect the spark plug cable - Turn "sava" to "sava" position - Refuel - Clean fuel supply - Clean, adjust or change the spark plug - Dry and adjust spark plug and start at full gas - Tighten the nuts 	<p>24</p> <p>BM</p> <p>BM</p> <p>BM</p>
The engine runs improperly	<ul style="list-style-type: none"> - Engine works with choke - Spark plug cable loose - Clogged fuel supply or bad fuel - Clogged tank drain - Water or dirt in fuel - Clogged air filter - Unadjusted carburetor 	<ul style="list-style-type: none"> - Turn "sava" to operating position - Properly install spark plug cable - Clean fuel supply, fill other fuel - Replace the plug - Drain tank and fill new fuel - Clean filter or put the new one - Set (adjust) carburetor * 	<p>24</p> <p>BM</p> <p>BM</p> <p>BM</p>
High engine temperature	<ul style="list-style-type: none"> - Low engine oil level - Difficult cooling - Clogged air filter - Unadjusted carburetor 	<ul style="list-style-type: none"> - Immediately refill oil - Clean the cooling system grid, clean the inner cooling fins * - Clean the air filter - Set (adjust) carburetor 	<p>BM</p> <p>29</p> <p>29</p> <p>BM</p> <p>BM</p>
Uneven work at high speed (gas)	<ul style="list-style-type: none"> - Short ignition interval - Improperly adjusted idle gear 	<ul style="list-style-type: none"> - Adjust spark plug - Set (adjust) carburetor * 	<p>BM</p> <p>BM</p>
The engine chokes in idle position	<ul style="list-style-type: none"> - Too long ignition interval, defective spark plug - Clogged air filter - Unadjusted carburetor 	<ul style="list-style-type: none"> - Adjust or change spark plug - Clean air filter - Set (adjust) carburetor * 	<p>BM</p> <p>BM</p> <p>BM</p>
The engine does not run smoothly	<ul style="list-style-type: none"> - Gas cable stuck or blocked 	<ul style="list-style-type: none"> - Clean the cable 	<p>BM</p>
The engine does not stop when shut down	<ul style="list-style-type: none"> - Shut-down system defect, no ground connection 	<ul style="list-style-type: none"> - Check cables and connections, check ground connection * 	<p>31</p>

6. Troubleshooting

Problem	Possible cause	Take action (repair)	Page
Engine has no power	- Clogged air filter - Loose cylinder head or damaged gasket - Low compression	- Clean the air filter - Tighten the cylinder head, replace the gasket - Check the engine	BM *
Clutch does not work	- Unadjusted clutch lever	- Adjust the lever stroke	32
Clutch slides	- Unadjusted clutch lever - Worn clutch (chain) layer	- Adjust the lever stroke - Change clutch (lamella) layers	32 *
Excessive vibration	- Loose screws	- Tighten the fixing nuts	34

* = for these actions, address FPM service department

BM = Honda Instructions Manual

Electric circuit, maintenance scheme (graph)

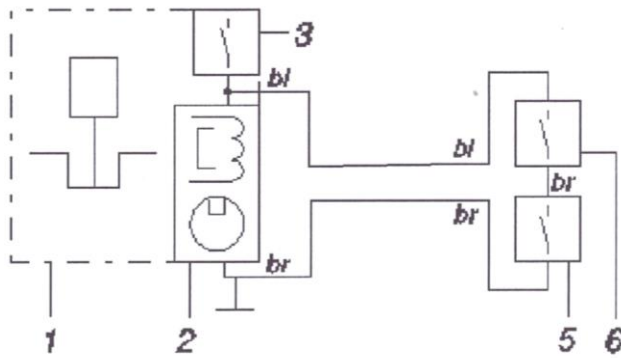

Safe electric circuit

1. Engine
2. Magnetic ignition system
3. Engine switch off button (on the engine gas lever)
4. Switch in safety lever
5. Switch in clutch lever

bl blue
br brown

Maintenance scheme

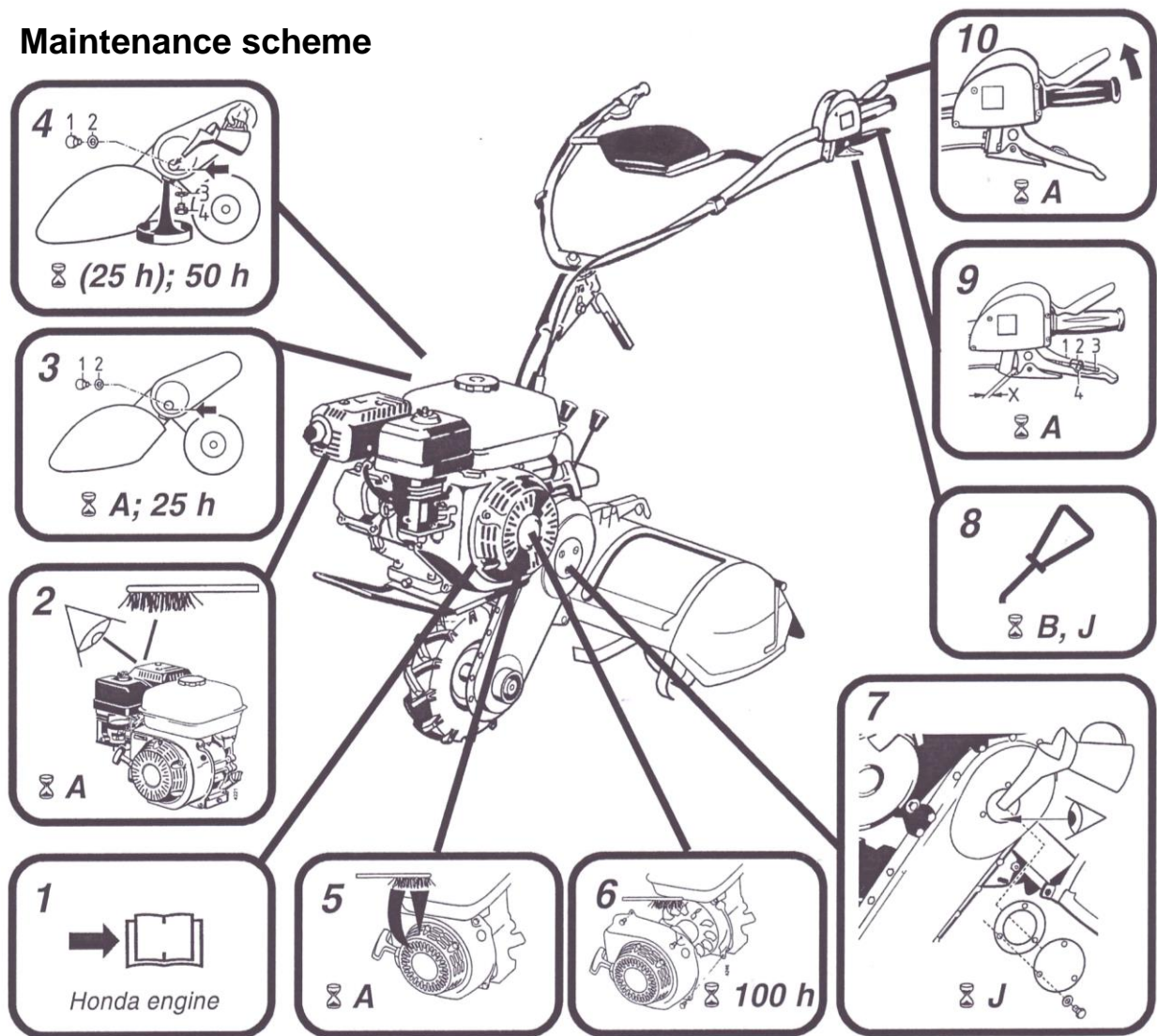

A = always before use
B = after each cleaning, particularly with high pressure
J = annually

Lubricants, varnishes, expendable parts

Order number.

Lubricating oil and fuel stabilizer

690 36	Bio lubricating oil	bottle	500 ml
799 09	Fuel stabilizer	bag	5 g



Please, read and study the provided instructions!

Urgent tire repair

713 13	Sealing gel Terra-S	bottle	1 l
--------	---------------------	--------	-----

Varnishes

181 03	Spray varnish light green	Can	400 ml
712 98	Spray varnish red RAL 2002	Can	400 ml
509 68	Spray varnish black	Can	400 ml

Expendable parts

761 99	Air-filter set		
759 99	Spark plug NGK BPR6 ES		
009 16	O-ring 16x22x1,5 (Gearbox oil control plug)		
536 48	O-ring of housing plug (change of oil)		
254 97	Hoes (cutting blades), left		
254 98	Hoes (cutting blades), right		

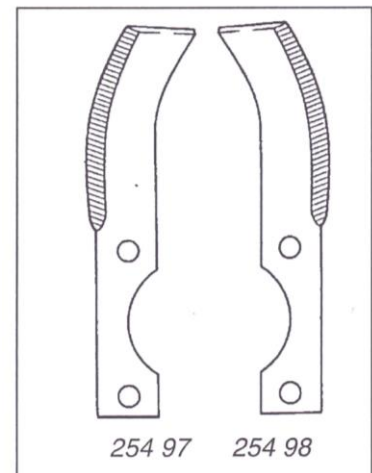

Spare parts

997 010	Motor hoes		
---------	------------	--	--

Inspection and maintenance list

	P	A	Always after working hours				Min. after 3 months	J	B	Page
			5	25	50	100				
Check turning-off (stopping) function	10	K							31	
Check clutch lever stroke	9	K							32	
Check air filter		K							BM	
Clean cooling grid	5	K							29	
Clean parts around the exhaust	2	K	K						29	
Check the engine oil level, Refill if necessary		K	K						BM	
Clean the gearbox connections (joints)		K		K			K		BM	
The first oil change			W						BM	
Later oil change					W				BM	
Cleaning				K					34	
Check the screws and nuts				K					34	
Check the gearbox oil level	3			K					30	
The first gearbox oil change, Later oil change	4			W	W				30 30	
Clean air filter				W			W		BM	
Change air filter parts if necessary					W				BM	
Clean spark plug, adjust the gap					W				BM	
Clean engine filter					K			K	BM	
Lubricate all sliding parts	8							K	K	34
Change spark plug						K			BM	
Clean air cooling system, earlier if necessary	6					W			29	
Check lubrication of chains for the drive wheel and tiller	7							W		30
Replace fuel hose								W*		BM

A = always before use

B = after each cleaning, particularly under pressure

J = minimum annually

K = checks and interventions by users

W = maintenance by service department

F = maintenance by FPM

BM = see instructions for engine

P = items in lubricants scheme

* = after two years

Marking of parts

Image (graph) C

1. Hexagon screw (bolt) for handlebar height adjustment.
2. Handlebar side adjustment clamping lever.
3. Engine switch-off button.
4. Safety lever
5. Clutch lever
6. Pawl
7. Gas lever

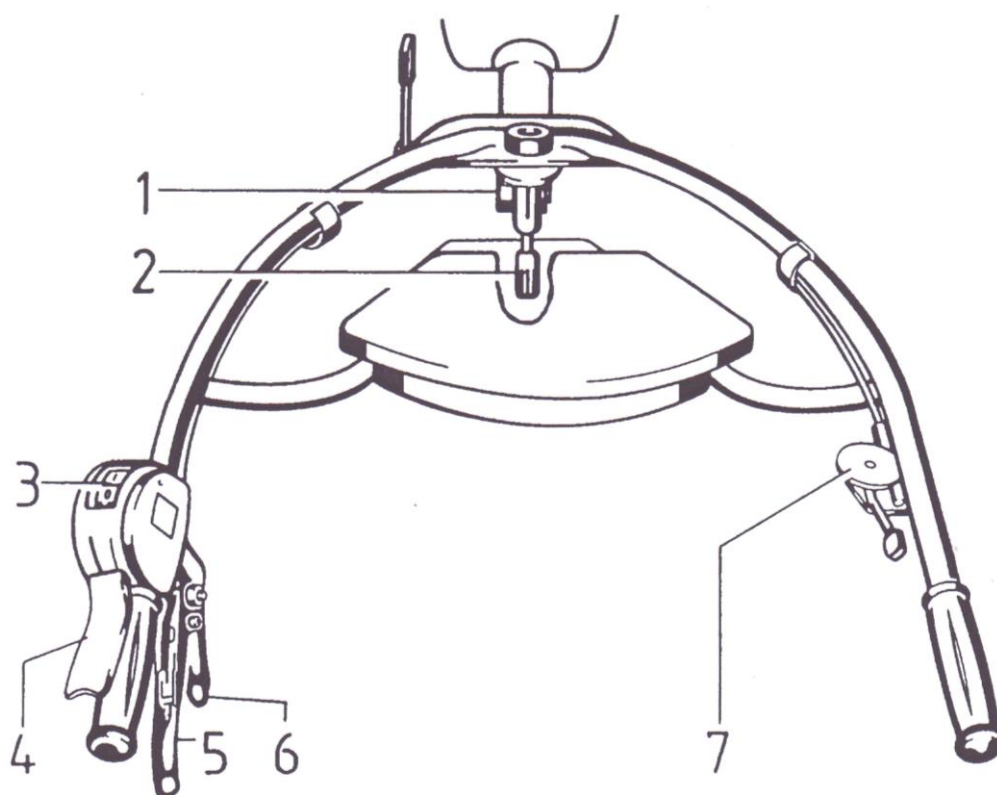



FPM AGROMEHANIKA DOO
Djordja Simeonovica 25
19370 Boljevac
Serbia

DECLARATION OF CONFORMITY 98/37/CE, 89/336/CEE, 2000/14/CE

We, hereby declare, within our responsibility, that the product

Type: Motor Hoes
Model: FPM 512

Year of production: 2009

is in compliance with all the relevant requirements defined by European Directive 98/37/CE, 89/336/CEE, 2000/14/CE.

The product complies with the following standards:

DESCRIPTION	STANDARD
Safety of the machines - basic concepts, general construction principles - part 1: Basic terminology and methodology	EN 292-1:1996
Safety of the machines - basic concepts, general construction principles - part 2: Technical principles and specifications	EN 292-2
Safety of the machines - safety limits defining danger zones with the machines	EN 294: 1995
Agricultural and forestry machinery – Pedestrian controlled tractors with mounted rotary cultivators; motor hoes with drive wheel (s) Safety	EN 709: 1997
Machinery for agriculture and forestry – Pedestrian controlled tractors with mounted rotary cultivators, motor hoes, motor hoes with drive wheel (s) – Safety – Amendment 1	EN 708:1996/A1:2001

In Boljevac,
20.09.2009.



Signature of the director
Branislav Rajic, BSc in Mech. Engineering



FPM AGROMEHANIKA AD
BOLJEVAC

Form 1

No.
2009

CERTIFICATE

SAFETY AT WORK MEASURES HAVE BEEN APPLIED

On: MOTOR HOES FPM 512

Type, series and purpose: Motor hoes for soil tillage in agriculture

Year of production: 2009

Technical data:

Attached documents: Instructions for handling, maintenance and safe work with the motor hoes with the List of spare parts and Warranty card

REMARK: Use the motor hoes in compliance with the instructions for handling and maintenance; no persons or animals are allowed in the operation zone. It is absolutely forbidden for the motor hoes to be operated by the unskilled persons, or persons with inadequate psycho-physical characteristics.

Authorized person

(Signature and seal)



FPM AGROMEHANIKA AD
BOLJEVAC

Form 1
No.
2009

CERTIFICATE

SAFETY AT WORK MEASURES HAVE BEEN APPLIED

On: MOTOR HOES FPM 512

Type, series and purpose: Motor hoes for soil tillage in agriculture

Year of production: 2009

Technical data:

Attached documents: Instructions for handling, maintenance and safe work with the motor hoes with the List of spare parts and Warranty card

REMARK: Use the motor hoes in compliance with the instructions for handling and maintenance; no persons or animals are allowed in the operation zone. It is absolutely forbidden for the motor hoes to be operated by the unskilled persons, or persons with inadequate psycho-physical characteristics.

Authorized person

 (Signature and seal)





The machine meets the relevant safety requirements of European directives for machines.



CAUTION: THIS SYMBOL IS USED IN THE MANUAL WHENEVER REFERRING TO YOUR PERSONAL SAFETY. BE CAUTIOUS!



**FOR YOUR OWN SAFETY AND TO GET ALL
THE BEST FROM YOUR MOTOR HOES, USE
ONLY ORIGINAL PARTS MANUFACTURED
BY FPM AGROMEHANIKA AD - BOLJEVAC**

FPM AGROMEHANIKA AD
19370 Boljevac, Djordja Simeonovica No. 25
TELEPHONES: Sales department: 030/463 455; 030/463 356
Service Department: 030/463 619
Export-import department: +381 (0) 30 463 531
FAX: +381 (0) 30 463 777